

PROJECT:

QTY:

ITEM No.

AFD 50/50 SPLIT CASE

DRY/REFRIGERATED FULL SERVE COMBINATION DISPLAY CASE

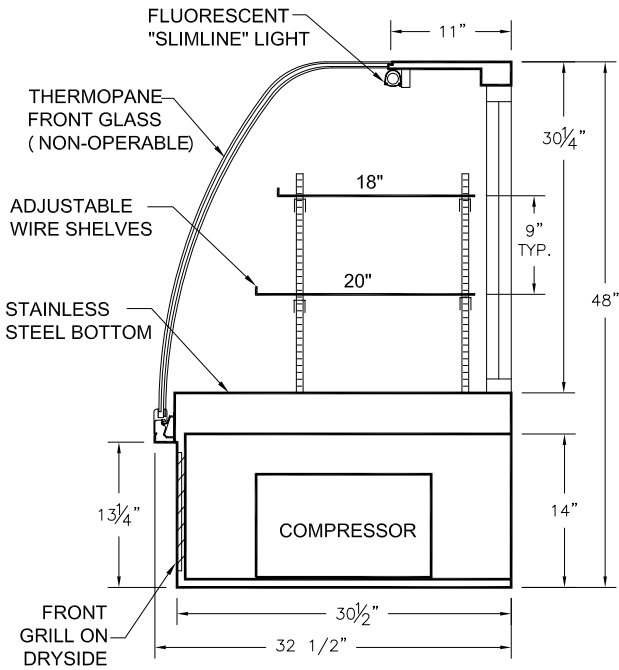

REF. SIDE VIEW

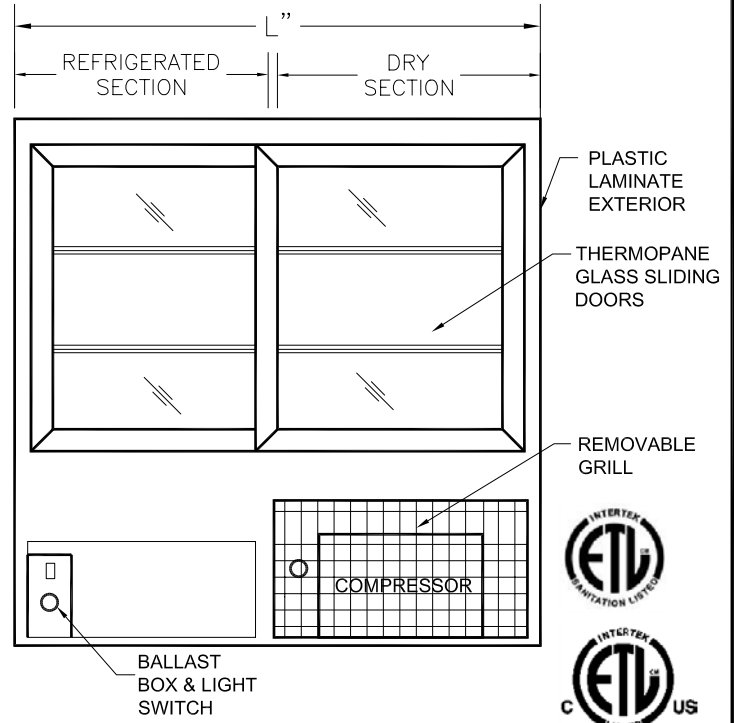

REAR VIEW



SPECIFICATIONS

DIMENSIONS	CVC	CVC	CVC	CVC	MODEL No.	MODEL No.
	3648FA	4848FA	6048FA	7248FA		
Length (in)	36"	48"	60"	72"	—	—
Depth (in)	32.50"	32.50"	32.50"	32.50"	—	—
Height (in)	48"	48"	48"	48"	—	—
ELECTRICAL						
Voltage	120	120	120	120	—	—
Amperes (Compressor and Light)	9.9	9.9	10.2	10.2	—	—
Amperes (Elect. Cond. Pan needs separate circuit)	—	—	—	—	—	—
Power Cord	8 ft.	8 ft.	8 ft.	8 ft.	—	—

NOTES

All Specifications subject to change without notice.

**Cases can be manufactured to custom sizes and widths for an additional fee. Ask your consultant for more information.

**Custom colors are also available.

** All units are designed to operate under normal store conditions of 24°C (75°F) with 50% relative humidity, and maintain the temperature between 35°F to 40°F.

**Condensation on glass may occur in Hot/Humid conditions. AFD is not responsible for any consequential damages as a result.

**AFD WARRANTY DOES NOT INCLUDE PRODUCT LOSS OR CONSEQUENTIAL DAMAGES HOWEVER CAUSED.



Advanced Fabrication & Design
 866-512-6747 p
 760-542-6403 f
 www.advanced-fabrication.com

DR. BY:

JIM

DATE:

4/16/09

FILE:

AFD5050FS